

SERVICEKIT

Salamander GENUINE parts

SKMECHA01 MECH



CT PUMPS

Salamander Pumps 

Making
water
perform



Instructions **VIDEOLINK:**



Salamander Pumps Shower Systems Limited

Unit 2c Colima Avenue, Enterprise Park West,
Sunderland, SR5 3XE

Telephone: 0191 516 2002

Facsimile: 0191 548 4445

Email: sales@salamanderpumps.co.uk

www.salamanderpumps.co.uk



PLEASE NOTE:

By using the parts included in this pack to repair your pump, you will be invalidating any warranty you have on the pump.

Returns:

If you need to return this pack for any reason please ensure the original packaging and these instructions leaflets are returned also. If you have any questions or queries regarding this spares pack or any other pump related questions please contact us.

UK:

Salamander Pumped Shower Systems Limited
Unit 2c, Colima Avenue Enterprise Park West
Sunderland SR5 3XE

Tel: 0191 516 2002

Email: tech@salamanderpumps.co.uk

Eire:

MTA agencies Ireland Fearn House,
Unit 4 Jamestown Business Park
Jamestown Road Finglas,
Dublin 11

Tel: +353 (0)1 864 3363

Email: service@mtagencies.ie

INTRODUCTION

All CT pump variants

Tools required :

- Pliers
- Seal Tool - XTOOLS 01
- M6 Allen bit/Wrench
- Torque Driver
- Soap Water Solution 5%

Parts in Service kit:

- Rotary Seal 10mm - SROTAR02 (14) x 2
- Static Seal 10mm - SSTATI02 (13) x 2
- Body O ring 59.6 mm OD - SORING17 (BOR) Blue EPDM (17) x 2
- Wire Clip- FWIREC01 (16) x 2
- 5. M6 Allen Bolt M6 X 45mm - FBOLTM04 (20) x 8
- M6 Spring Washer- FWASHE03 (21) x 8
- Filter Washer-SFILTE01 (26) x 2
- Rubber Washer-SFLATW01(25) x2
- Seal Tool - XTOOLS01

WARNING! ENSURE PUMP IS ISOLATED FROM ELECTRICITY AND WATER SUPPLY. IF IN DOUBT CONSULT A COMPETENT TRADESMAN.

Pump should be serviced in horizontal position with couples disconnected and water and electricity supply isolated.

DO NOT RUN PUMP DRY. ALLOW WATER TO FILL PUMP TO LUBRICATE SEALS BEFORE STARTING. CHECK FOR LEAKS DURING TEST BEFORE BEING SATISFIED PUMP IS OK

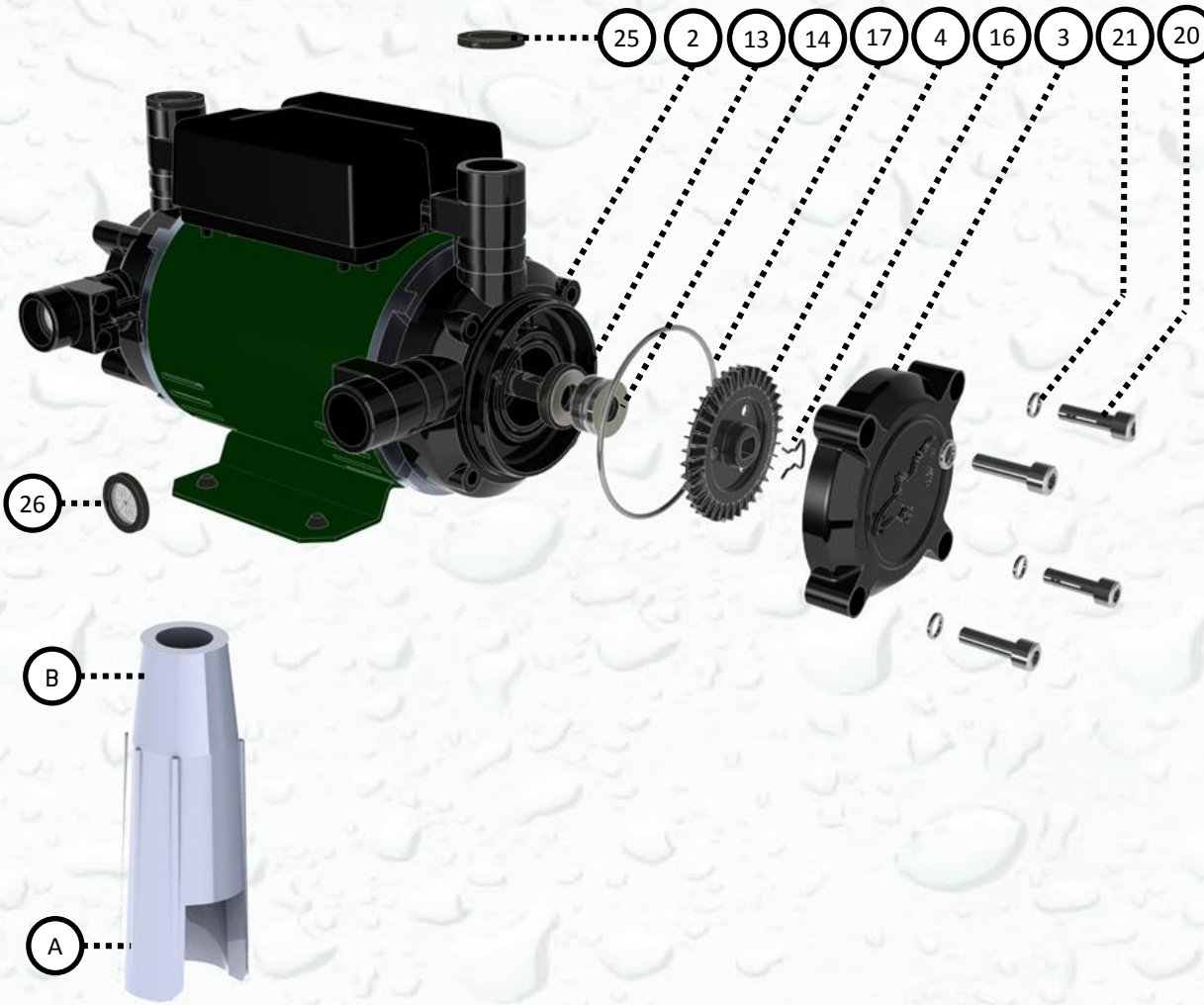

Seal Tool - XTOOLS - 01

1. Remove x 4 M6 Bolts (20) and spring washers (21)
2. Remove Cover (3) noticing its orientation. Remove and discard O ring (17).
3. Remove Impellor (4) noticing its orientation. The impellor may be difficult to remove and may require a puller or two levers .i.e. Flat screwdrivers to lever off carefully.
4. Notice wire clip (16) position and remove wire clip and discard.
5. Remove rotary seal (14) and discard.
6. Remove static seal (13) and discard.
- (Do not damage seal housing areas or shaft !!)**
7. Remove any debris and clean thoroughly all exposed areas.
8. Lubricate Inner seal area and shaft with soap water solution.
9. Carefully place the new static seal over shaft and press into housing ensuring flat against seal housing area and level using Seal Tool end A.
10. Separate the new rotary seal into seal, spring and cap.
11. Place seal over shaft with carbon face on the underside.
12. Push seal into place using seal tool end B.
13. Refit New spring and cap onto rotary seal.
14. Compress spring pressing seal tool A onto the cap, exposing the clip slot and push new wire clip into its previous location slot on the shaft using long nosed pliers through the seal tool aperture.
15. Refit impellor in the same orientation it was removed.
16. Fit new Blue BOR(17) ensuring it is not rolled and fully in place.
17. Refit cover ensuring level.
18. Secure cover with new M6 Allen bolts and new spring washers by driving diagonally opposite in stages to a Torque of: 1.7Nm. - 2.4Nm
19. Repeat for opposite side if required .Replace filter (26) and rubber washers(25) before reconnecting couplers. Service is now complete and pump ready for test.